

# EASTERN

Powered by EcoBurner

## Product Catalog

EXPLORE OUR WATERLESS BUFFET COLLECTION FOR 2025



Powered by EcoBurner

# EASSTERN

TABLETOP

# Contents

EcoBurner Goals	5
EcoBurner and Fuel	6
EcoHold	11
EcoServe	18
EcoServe Classic	20
EcoServe GN	28
EcoServe Round	36
EcoPan	42
5-Star Rolltop Chafers	43
EcoTile	44
EcoBurner with EcoBoost	48
Coffee Urns	49
Savings	51
Testimonials	53
Support Products	54
Online Supports	55

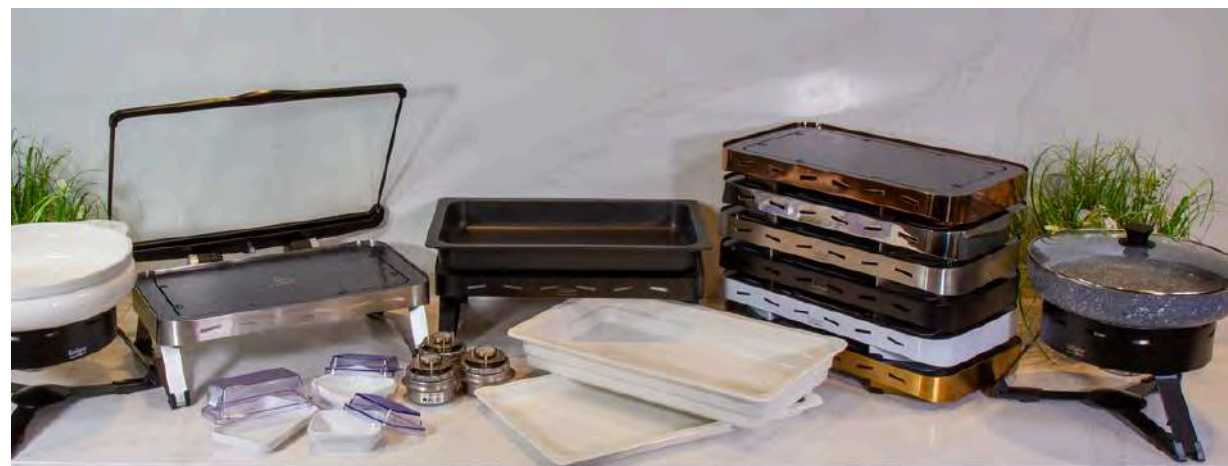



# Go GREEN with Eastern Tabletop

For over 70 years, Eastern Tabletop has been a trusted supplier of high-quality products to the U.S. hospitality industry, consistently innovating in buffet equipment. Their partnership with EcoBurner introduces eco-friendly solutions to buffet setups, with their products reducing carbon emissions by up to 75% and eliminating the need for water and single-use items.

By offering buffet equipment powered by EcoBurner, Eastern Tabletop is helping hospitality venues embrace sustainable practices and reduce their environmental impact.

■  
**EcoBurner**

---

We believe gels and wicks have no place in modern hospitality. They can be dangerous for staff to handle and are detrimental to our precious environment.



## Stop using Gels & Wicks

So much waste is created by using gels and wicks. They are usually only used once and disposed of after every service. This is unacceptable in today's world of hospitality.

As hotels and catering venues strive to eliminate single use items, these gel and wick pots need to go.

## Stop wasting WATER

An average water-based chafers uses approximately 0.264 US Gal of water every hour of use and this water needs to be heated, transported and disposed of which is very wasteful.

EcoBurner equipment uses hotplate technology instead of water pans to disperse the heat so water based chafers are no longer necessary.

# What is EcoBurner

A refillable burner that provides portable heat for buffet food.

The EcoBurner is refilled with EcoBurner fuel after service so that every drop of fuel is used or saved for the next service. Each can of EcoBurner fuel gives up to 36 hours of burn time.

It's a SAFER CLEANER & GREENER alternative to single-use gels and wicks.



EcoBurner #EB18999



EcoBurner Fuel #EB19009



# Switch to EcoBurner

The call to eliminate gel and wick pots from hospitality settings is getting louder. Hotel managers realise the dangers of having their teams handle these pots of chemicals near food and most have heard stories of terrible injuries resulting from the mishandling of these single-use items.

EcoBurner is different, it's the safer, cleaner and greener option for staff to handle and guests to be around.



## SAFER

- Always cool-to-touch.
- Switches off if overturned or over-heats.
- No open chemicals near food.



## CLEANER

- No black, smoky residue left on cookware.
- No toxic fumes = pleasant atmosphere for guests.
- No messy fuel spills.



## GREENER

- Zero Fuel Waste.
- Zero Waste to Landfill.
- Up to 75% less Carbon than gels or wicks



1 can EcoBurner fuel = 18 gel/wick pots

LIMERICK STRAND HOTEL, IRELAND







CAPELLA SENTOSA SINGAPORE

# Four ways to use EcoBurner and switch to sustainable buffets!



■ **EcoHold**  
Banqueting Cart



■ **EcoServe**  
WATERLESS  
Chafers



■ **EcoPan**  
Water pan replacement  
for existing chafers



■ **EcoBoost**  
Bracket to use EcoBurners  
with existing equipment

# EcoHold

Powered by EcoBurner

Banqueting cart that caters for either HOT or COLD service

**WITH THERMOFLEX TECHNOLOGY**

EcoHold32 #9200





# Premium Banqueting

The EcoHold is a premium banqueting cart designed to keep food hot or cold, offering unmatched performance for foodservice operations. Built with durable, high-grade steel, it is engineered to withstand the demands of commercial kitchens. This innovative cart is packed with clever features that enhance functionality, streamline foodservice, and ensure optimal food quality, making it a revolutionary addition to any professional catering environment.



## Foot Pedal

Doors open using a foot pedal for easy, hands-free access to dishes.



## Thermometer

Mechanical built-in thermometer to monitor temperature of cart.



## Glass Doors

Both doors feature double-glazed, toughened, and insulated glass, offering a complete view of contents.



## Lockable

Doors can be locked for stability during transport and to ensure food integrity.



## Handrail

Wrap-around handrail and rubber bump rails on all corners for effortless transport and handling.

# EcoHold 32

## Standard Capacity

Each EcoHold is designed to accommodate up to 32 GN 1/1 food pans, making it ideal for serving buffets at large-scale events.

Please note that these standard-sized food pans are not included with the EcoHold 32 but can be easily purchased separately.

**Weight:** 496lbs when empty

**External:** (WxDxH): 42.1" x 33" x 75.3"

**Internal:** (WxDxH): 34.2" x 27.4" x 63"

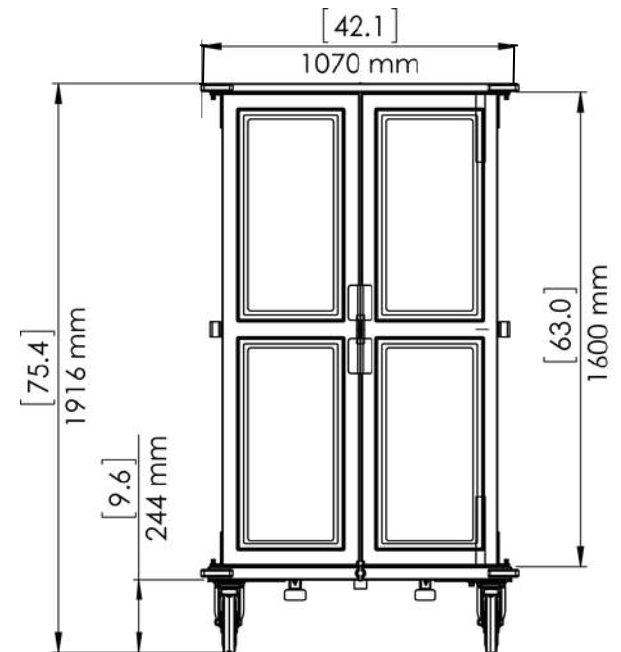

# Plated Service



# EcoHold 32 Plated Service

Every EcoHold includes 32 perforated pans that can be used for plated service. These pans hold a max of **64 dinner plates** (28cm diameter) or **96 appetiser plates** (20cm diameter).

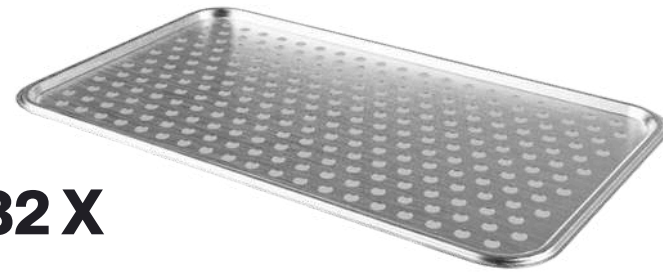

**32 X**

Included as standard



## Expansion Kit

Available to order to increase plated capacity

An Expansion Kit is available to order separately to increase the capacity of plated service. The pack contains an extra 32 perforated pans and 64 extra rails to fit the pans on.

This doubles the capacity to **128 dinner plates** (28cm diameter) or **192 appetiser plates** (20cm diameter).

EcoHold 32 Expansion Kit #5341

# Powered HOT by up to 6 EcoBurners



- No electricity, batteries, or cables required.
- Even heat distribution achieved through controlled venting ensures every dish stays hot for at least five hours.
- Continuous heat during transportation.
- Temperature of the cart can be adjusted by adding EcoBurners to increase heat or removing them to reduce it.
- Safety features remain functional during use.



- No electricity, batteries, or cables required.
- EcoHold comes with 10 reusable Cool Packs for CHILLED service, which are also compatible with EcoServe GN 1/1.
- The frozen Phase Change Material (PCM) used in the cool packs keeps the EcoHold cart cold for at least five hours, ensuring food safety and quality.
- Maintains an even chilled temperature throughout service and transportation.



Powered  
COLD by  
10 Cool  
Packs  
(included)



# EcoServe

Powered by EcoBurner

EcoServe offers a range of WATERLESS chafing dishes that cater to every style.

## WATERLESS

Stop wasting water, time, energy and cost.

## WINDPROOF

Perfect for outdoor dining and no more wrapping chafers in foil to avoid the wind.

## QUICK & SAFE

Heats up quickly, easily swap dishes and no electricity or hazardous cables required.

## FLEXIBLE

Caters for large or small events. The buffet can be built to your style and requirements.





## EcoRock

8QT Rectangle  
6QT Square  
6QT Round

The EcoServe Classic range combines the timeless appeal of traditional chafing dishes with modern eco-friendly benefits. Offering zero water usage, zero waste generation, and a reduced carbon footprint, it's a sustainable choice without compromising style.

Available in three sizes, the range provides chefs with options to suit any catering setup.



## GN

Rectangle  
Six Finishes



The EcoServe GN is expertly crafted for commercial kitchens, designed to accommodate standard GN 1/1 sizing. With its minimalist styling and six elegant finishes—White, Black, Brushed Stainless Steel, Polished Stainless Steel, Gold PVD, and Copper PVD—it appeals to a variety of style preferences, making it a versatile choice for any buffet setup.



## Round

Large & Small  
Six Finishes



The EcoServe Round offers a choice of large and small sizes with varying heights and is available in the same six stunning finishes as the EcoServe GN - White, Black, Brushed Stainless Steel, Polished Stainless Steel, Gold PVD, and Copper PVD. This allows chefs to mix sizes and finishes to craft unique and personalised dining experiences that reflect their individual style.



## EcoRock WATERLESS Chafers

Experience the timeless elegance of traditional hinged chafing dishes with the added sustainability of our waterless design. Perfect for venues seeking a classic look while minimising their environmental impact.





## 8QT Rectangle

**Glass Lid #EB15375G**



## 6QT Square

**Glass Lid #EB15374G**



## 6QT Round

**Glass Lid #EB15378G**



Each EcoServe Classic chafer is equipped with 4 connectors for easy stacking, making storage simple and convenient.

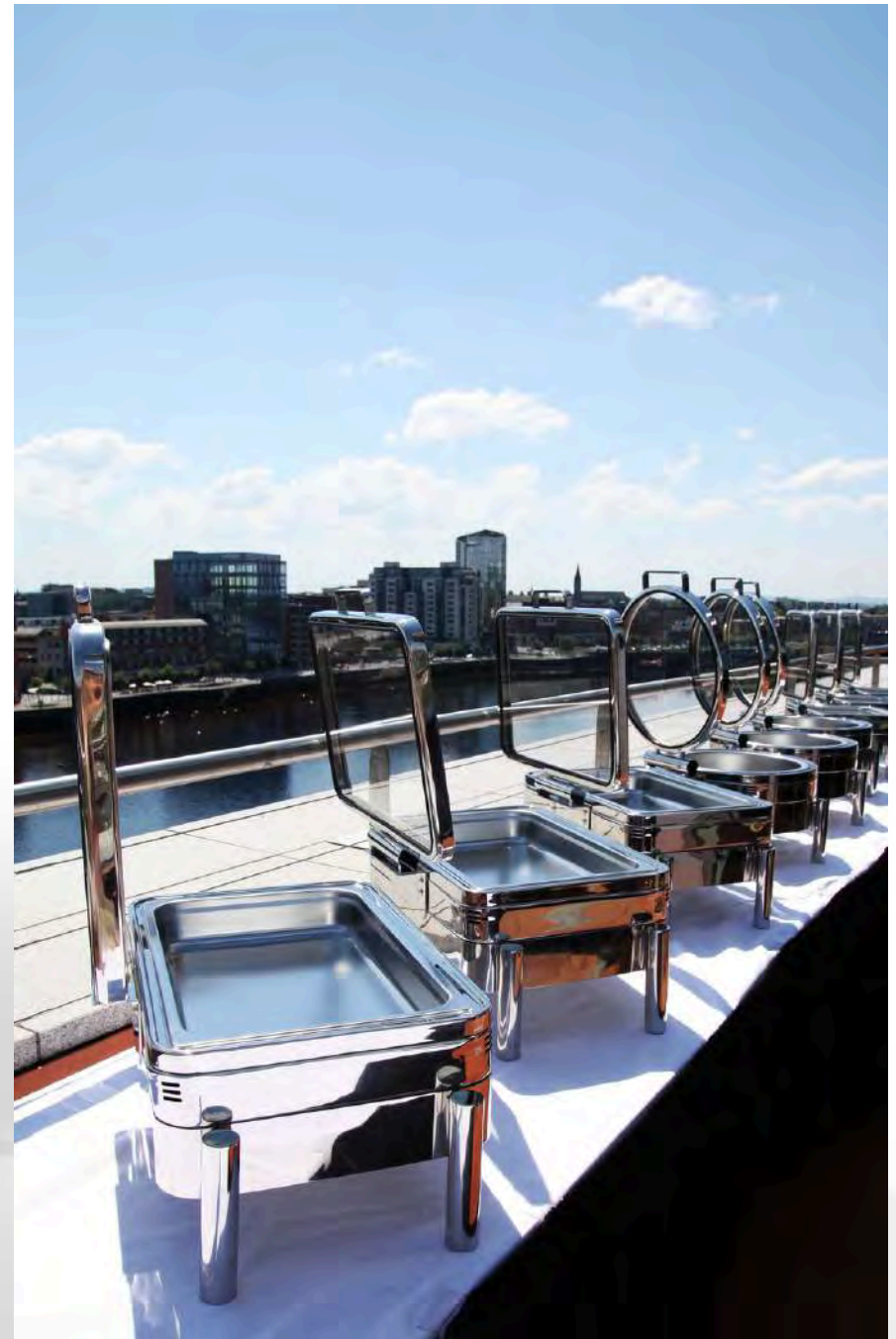

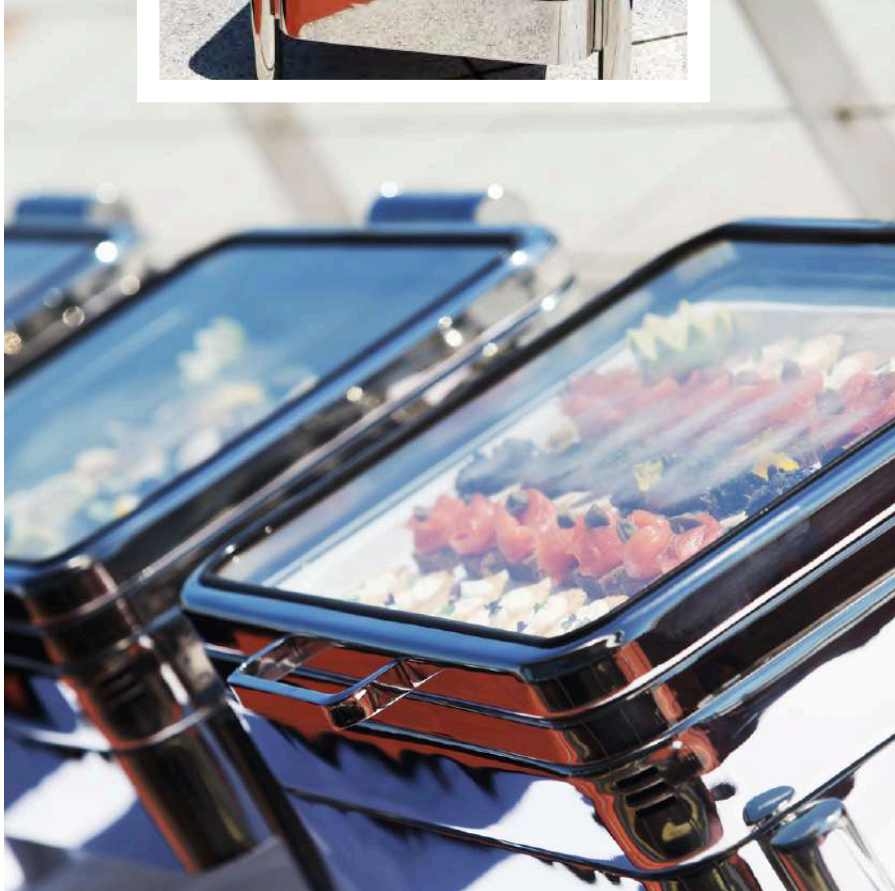



Pearl Black Neofusion  
Porcelain Dish - GN 2/3

#EB15406



White Porcelain  
Dish - GN 2/3

#EB15404



## Square GN 2/3 Porcelain Dishes

To complement the EcoRock  
WATERLESS Chafer 6QT  
SQUARE





Pearl Black Neofusion  
Porcelain Dish - ROUND

#EB15407



White Porcelain  
Dish - ROUND

#EB15405



## Round Porcelain Dishes

To complement the  
EcoRock WATERLESS  
Chafer 6QT ROUND

# Premium Porcelain Dishes GN 1/1

To complement the **EcoRock and GN** ranges of WATERLESS chafers. Also compatible with the **EcoTile** #EB1807GB



White 2" Deep

#EB15400



White 2" Divided

#EB15401



White Shallow Serving Platter

#EB15209



Pearl Black Neofusion 2"

#EB15402



# Premium non-stick aluminium dish GN 1/1 - Lunar Black

To complement the **EcoRock and GN 1/1** ranges of WATERLESS chafers, the aluminum dish is an ideal choice for venues seeking a more robust alternative to porcelain dishes.

Silicone-coated utensils are also available for order, specifically designed to protect the dish's coating during heavy use.



#EB15336



Silicon coated  
Stainless Steel  
Tongs - Pack of 5

#EB15408



Silicon coated  
Stainless Steel  
Ladle - Pack of 5

#EB15410



Silicon coated  
Stainless Steel  
Spatula - Pack of 5

#EB15409





## EcoServe GN

With its minimalist design, the WATERLESS EcoServe GN is the ultimate choice for venues seeking a stylish, hassle-free buffet solution that's effortless to operate, store, and maintain.



**REINFORCED GLASS**  
For commercial use

**ADJUSTABLE LID HEIGHT**  
To accomodate various height dishes

**SILICONE MAT**  
To protect hot plate and create a non-slip surface for dishes

**FOLDABLE LEGS**  
For stackable, compact storage

**SILICONE FEET**  
To ensure non-slip

**CONDENSATION CATCHER**  
To reduce moisture in food

**REMOVABLE GLASS LID**

**SOFT CLOSE HINGE**



#5311

Reinforced Glass Lid



#5320

 Powder-coated  
BLACK



#5313

 Powder-coated  
WHITE



#5316

 Polished Stainless  
Steel



#5314

 Brushed Stainless  
Steel



#5317

 GOLD PVD



#5318C

 COPPER PVD



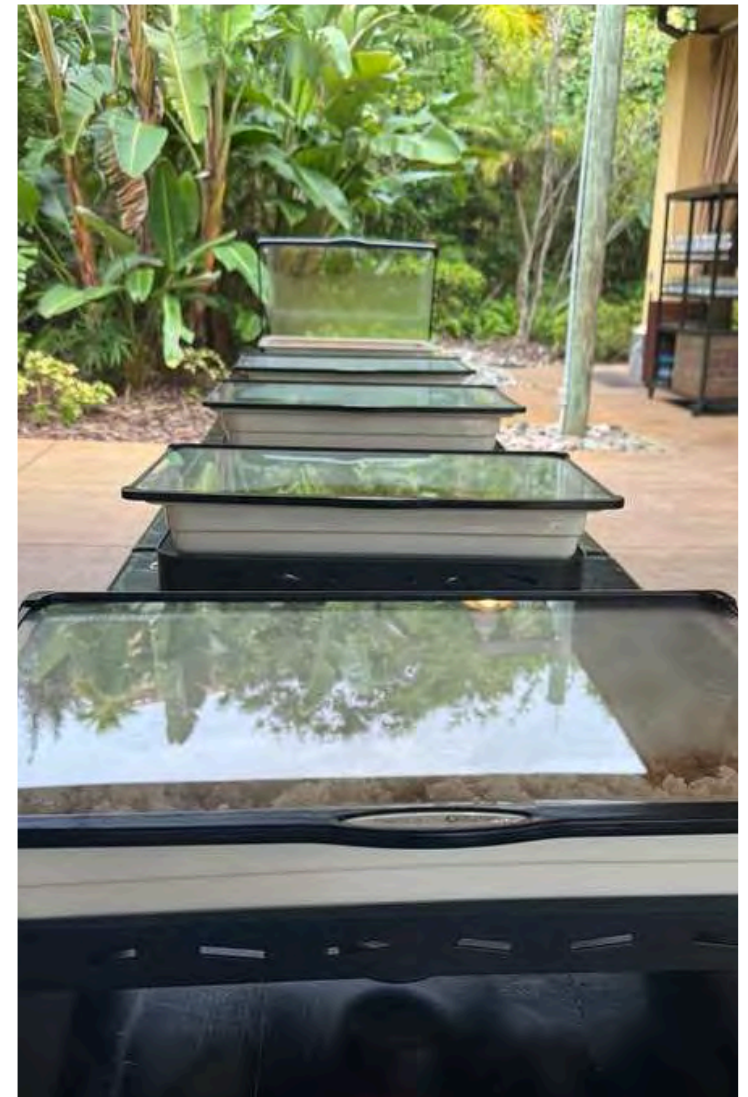

LOEWS ROYAL PACIFIC RESORT, ORLANDO UNIVERSAL STUDIOS



SOLANA BEACH, MAURITIUS



# Single-Serve Dishes

To complement the EcoServe GN 1/1 range of WATERLESS chafers, these individually portioned dishes are ideal for the grab and go trend that's here to stay.



Square

Dish #EB15326  
Lid #EB15329

8 Dishes per GN



Small

Dish #EB15324  
Lid #EB15327

12 Dishes per GN



Large

Dish #EB15325  
Lid #EB15328

6 Dishes per GN



EL PATRON MEXICAN RESTAURANT,  
ORLANDO, FLORIDA, USA

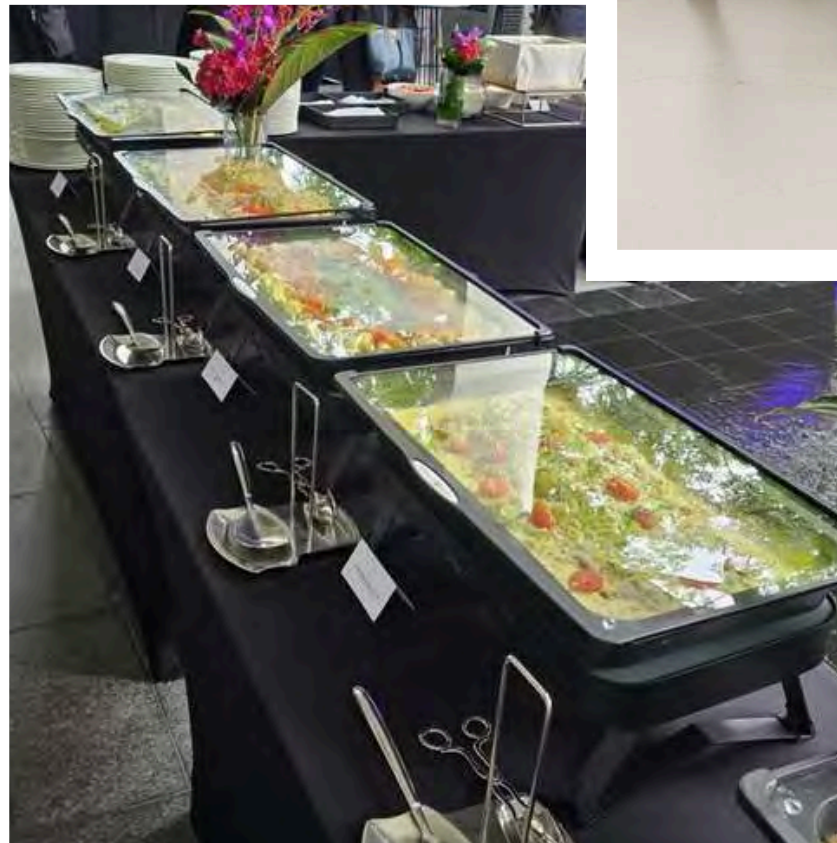

THE CAPELLA HOTEL,  
SINGAPORE

# Powered COLD by Cool Packs



## EcoServe GN COOL PACK



#EB15322

Simply freeze the GN COOL PACK, and place it directly on the GN hot plate. Then, place pre-chilled dishes on top. This simple process allows users to effortlessly switch to cold service using the same equipment.

Ideal for serving seafood, salads, fruits, and desserts!





THE PARKROYAL COLLECTION,  
MARINA BAY, SINGAPORE



## EcoServe Round

Matching the EcoServe GN's six finishes, the round versions provide versatile buffet solutions with large and small sizes, empowering chefs with greater choice to style their buffets uniquely.





PARKROYAL COLLECTION MARINA BAY, SINGAPORE



Large #EB15005  
Small #EB15004

■ Powder-coated  
BLACK



Large #EB15007  
Small #EB15006

□ Powder-coated  
WHITE



Large #EB15016  
Small #EB15015

■ Polished Stainless  
Steel



Large #EB15009  
Small #EB15008

■ Brushed Stainless  
Steel



Large #EB15014  
Small #EB15013

■ GOLD PVD



Large #EB15012C  
Small #EB15011C

■ COPPER PVD

VÉRANDA PAUL ET VIRGINIE  
HÔTEL MAURITIUS

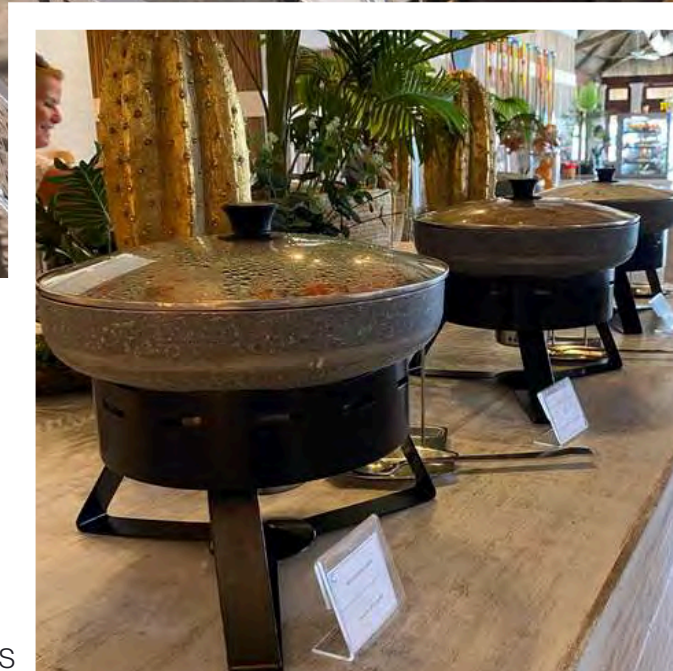
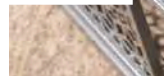

EMIRATES PALACE HOTEL ABU DHABI

# Premium Non-Stick Aluminium Dishes

These premium aluminium dishes are designed to dock securely into the EcoServe Rounds to ensure maximum heat transfer and minimal movement.



Arctic Grey  
Large #EB15210  
Small #EB15211



Black Moonscape  
Large #EB15218  
Small #EB15219



Round Glass Lids  
Large #EB15302  
Small #EB15301



Pot Lid/ Spoon Rack  
#EB15300



# Powered COLD by Cool Packs



## EcoServe ROUND COOL PACK



#EB15305

Simply remove the hotplate and the heat pan from the EcoServe Round and place a frozen COOL PACK onto the EcoServe frame and you can easily switch to cold service.

Perfect for seafood, salads, fruit and desserts!







CAPELLA SENTOSA,  
SINGAPORE



# EcoPan

Powered by EcoBurner

Each EcoPan **saves 581 US Gal** of water every year if used instead of a waterpan!



Use existing food pan



Drop in NEW EcoPan



Use existing Chafer



## Go WATERLESS using your existing chafers

Simply remove the water pan from existing chafers and replace it with an EcoPan to create a WATERLESS Buffet. This is a cost-effective method of going WATERLESS with minimal spend on new equipment.



EcoPan x 5 #EB15330



### INDOORS

Only 1 EcoBurner is needed for indoor buffets.



### OUTDOORS

Use 2 EcoBurners outdoors.



# WATERLESS 5-star RollTop Chafers

Now you can use Eastern Tabletop chafing dishes with an **EcoPan** to create a WATERLESS chafer, powered by EcoBurner instead of single-use gels or wicks.

The high quality chafing dishes you know and love can now add to your sustainability goals too by reducing carbon and waste and eliminating water completely.



Pillar'd Waterless  
rolltop Chafer

#EE3124



P2 Waterless rolltop  
Chafer

#EE3144



Park Avenue Waterless  
rolltop Chafer

#EE3114



Queen Ann Waterless  
rolltop Chafer

#EE3114QA

# EcoTile

Eastern TableTop offers a collection of collapsible buffets including the **ZOZZ**, **HUB**, and **Q-BIK** mobile units. With an interchangeable tile system, customers have the flexibility to switch out tiles among these three units based on their specific functions and desired locations.

EcoBurner is compatible with three of these tiles that can be used to make these systems more sustainable by eliminating water and carbon and waste.



3 tiles to choose from that are powered by EcoBurner and compatible with all Eastern mobile buffet systems!



Single round warming tile

#EB1804GB

A tile with a single round hotplate allows customers to use one large round dish on any of the three mobile buffet systems. Simply clip an EcoBurner into the clips underneath for a consistent heat that keeps food warm anywhere!



Double round warming tile

#EB11803GB

A tile with two round hotplates allows customers to keep two dishes of food hot at the buffet by simply clipping EcoBurners into the clips underneath for a consistent heat that requires no electricity or cables and can be moved to any location.



GN warming tile

#EB1807GB

The EcServe GN (sold separately) fits into the EcoTile GN and is then used on any of the ZOZZ, HUB or Q-BIK mobile buffets. EcoBurners are then clipped into the EcoServe GN to provide the heat source.





# EcoBurner with EcoBoost MINI

Replace single-use gels or wicks for zero waste and less carbon! Simply attach an EcoBoost MINI bracket to the top of an EcoBurner and place it under existing chafing dishes for improved sustainability.

Using only the EcoBurner with an EcoBoost MINI under any existing chafing dish will still **reduce carbon and waste** and make the buffet a safer system.



EcoBoost MINI #EB11139



### Grill-type chafers



Use 1 EcoBurner on low with an EcoBoost MINI bracket under grill-type chafers. This will give a consistent, radiant heat that's perfect for foods that need more controlled heat such as melted cheese.



### Hinged chafers



Use 2 EcoBurners on high with EcoBoost MINI brackets under traditional hinged chafing dishes. These are used instead of gels or wicks to reduce carbon by 75% and eliminate waste completely.



### Roll-top Chafers



Use 2 EcoBurners on high with EcoBoost MINI brackets under roll-top chafing dishes. Simply replace the single-use gels or wicks for a safer, cleaner and greener buffet.

# Stop using gels & wicks on any buffet!



# Coffee Urns

The Eastern range of coffee urns can now be heated using the EcoBurner with an EcoBoost MINI clipped on to the top for more efficient and consistent heat.



An EcoBoost MINI is required for efficient heating of coffee urns



5-star Jazz Rock collection

**5 Gallon #3285**  
**3 Gallon #3283**



4-star Ballerina collection

**5 Gallon #3135**  
**3 Gallon #3133**  
**1.5 Gallon #3131**



4-star collections Park Avenue

**5 Gallon #3115**  
**3 Gallon #3113**



4-star collections Pillar'd

**5 Gallon #3125**  
**3 Gallon #3123**



4-star collections P2

**5 Gallon #3145**  
**3 Gallon #3143**





# SAVINGS from 1 Chafing Dish in 1 Day

WATERLESS equipment is more sustainable and reduces operating costs by requiring just one EcoBurner heat source instead of two gels/ wicks.



1 chafer



Twice a day

1 chafer in use for 3-hour service, twice a day = 6 hours per day

## WATER

1 water-based chafing dish uses an average of 0.264 US Gal of water every hour. That's 1.58 US Gal of water wasted every day if traditional chafers are used. This is easily prevented by switching to EcoServe WATERLESS chafers.



**1.58 Gal**

Water saved

## WASTE

1 water-based chafing dish uses an average of 4 gels over a 3-hour service, twice a day = **8 gels every day.**



At the end of service, these pots, some still containing toxic chemicals, often go straight to landfill, weighing approximately 1.8oz each.

This is 14.4oz of waste per chafing dish created unnecessarily every day.

**8 gel pots**

14.4oz waste prevented

## CARBON

EcoBurner fuel has been independently tested by Carbon Footprint against industry standard gels and wicks with the following resulting emissions per day (2 x 3-hr services).

	kgCO <sub>2</sub> e
<b>EcoBurner Fuel:</b>	<b>0.32</b>
DEG:	0.93
Methanol:	0.82
Ethanol:	1.15
<b>Average gel/wick:</b>	<b>0.97</b>

EcoBurner emits 0.32 kgCO<sub>2</sub>e of carbon a day if used for 6 hours. This is compared to the average of gels/ wicks emitting 0.97 kgCO<sub>2</sub>e. This results in 0.65 kgCO<sub>2</sub>e less carbon every day from only 1 chafing dish.

**0.65 kgCO<sub>2</sub>e**

Less Carbon

## COST

Cost is based on average price of \$2.08 per gel pot.

8 gels are needed per day so cost of gels is **\$16.64**

**\$2.08 multiplied by 8 = \$16.64**



Cost is based on average price of \$15.83 per 36-hr EcoBurner fuel can.

6 hours burn time are needed per day so cost of EcoBurner fuel for 6 hours is **\$2.64**

**\$15.83 divided by 6 = \$2.64**

**\$16.64 minus \$ 2.64 = \$14**



**\$14**

Dollars saved





## Chef William Pfeiffer

Executive Chef & Beekeeper,  
FLIK Hospitality Group

“With a traditional gel or wick, you get one single heat source that wants to heat whatever is directly above it, but with EcoBurner, you get an adjustable radiant heat with no burn spots.”



### AT A GLANCE

#### CHALLENGES OF GELS

- Inconsistent heat
- Not suitable for outdoors
- Hugely wasteful & hard to dispose

#### BENEFITS OF ECOBURNER

- Consistent, adjustable heat
- Refillable so ZERO WASTE
- More cost-effective
- Saved \$90.18 (59%) on fuel from 1 buffet event!



## Matthew Darnall

Director of Food & Beverage, St.  
Andrews Country Club,  
Boca Raton, Florida

“...the club has saved approximately 3,000 sternos from going into landfills since they started using EcoBurner less than a year ago. That's a really significant prevention of single-use items hitting our landfills.”



# Support Products

EcoBurner is the most sustainable method of portable heat for buffets but just like any equipment, it's important staff know how to use it correctly.

The filling station is essential for checking fuel levels, while the Storage Rack, SOP sticker, EZFill, and Storage Trolley work together to help venues establish clear systems. These ensure staff always know how to use, store, and maintain EcoBurners, allowing everyone to continue enjoying the benefits.



Filling Station

A filling station is provided free of charge to all venues using EcoBurners. Staff must use it to measure fuel levels before and after refilling every EcoBurner.



#EB19502



Storage Rack

Use the EcoBurner Storage Rack to securely store up to 8 EcoBurners. Follow the laser-marked instructions for proper storage. Racks are stackable for efficient organization.



#EB15337



SOP Stickers

Free SOP stickers are provided to display near the EcoBurner storage area, giving staff clear instructions on filling, storing, and using EcoBurners.



#EB19962



EZFill

EZFill is a smart solution for effortless EcoBurner refills. Simply place the fuel can upside-down, align it with the EcoBurner, and lightly pull the lever for a smooth refill.



#EB19509



Storage Trolley

The storage trolley holds up to 15 storage racks (120 EcoBurners) and provides an efficient back-of-house space for storing, refilling and organising everything needed for EcoBurners.



#EB15393

# Continued Online Support

With frequent staff turnover in hospitality, we provide ongoing training and support for EcoBurner users. Comprehensive online resources ensure safe, continuous use. For any issues, follow our simple 3-step process to resolve them quickly.

---

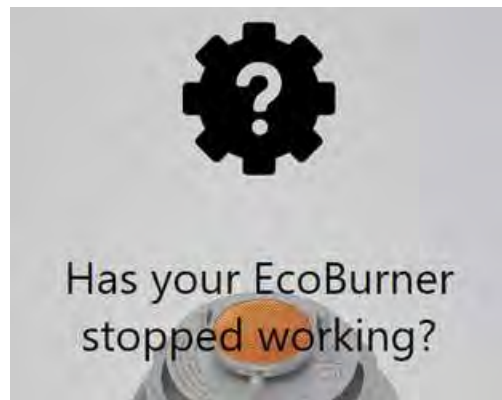

## Step 1

Watch the Instruction Video  
(2:24 mins)



## Step 2

Go through TROUBLESHOOTING  
if your EcoBurner is not working.



## Step 3

Talk to an EcoBurner expert for  
further support and training.



Member of  
**WORLD ALLIANCE**  
*for* EFFICIENT SOLUTIONS | by **SOLARIMPULSE**  
FOUNDATION



EcoBurner has been awarded the “Solar Impulse Efficient Solution” Label, a proof of high standards in profitability and sustainability.

Solar impulse identified 1000+ clean and profitable solutions to address environmental issues without compromising on economic growth and EcoBurner is one of them! This is thanks to the WATER and CARBON savings achieved by using the EcoBurner system instead of gel and wicks.

To receive the “Solar Impulse Efficient Solution” Label, EcoBurner was thoroughly assessed by a pool of independent experts according to 5 criteria covering the three main topics of Feasibility, Environmental and Profitability. All labelled solutions are part of the #1000solutions portfolio that are presented to decision-makers in business and government by Bertrand Piccard, Chairman of the Solar Impulse Foundation. The aim of this initiative is to encourage the adoption of more ambitious environmental targets and fast-track the implementation of these solutions on a large scale.

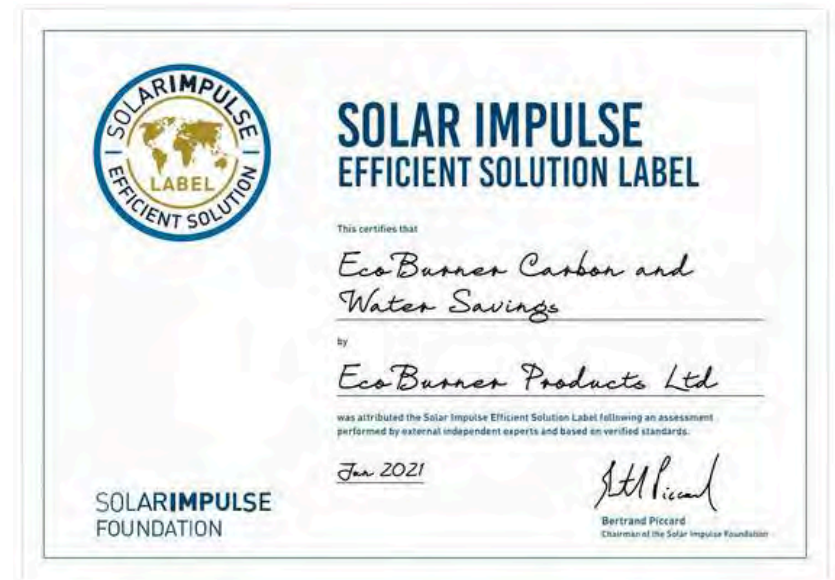





WE ARE PART OF THE  
**#1000SOLUTIONS**  
TO CHANGE  
**THE WORLD**





Scan here for a full Product list including product codes, weights and dimensions.

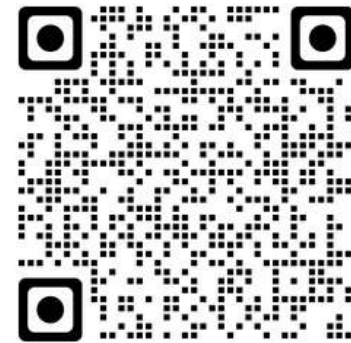



**EASTERN**  
Powered by EcoBurner

[www.us.ecoburner.com](http://www.us.ecoburner.com)

## Contact Us

[sales@easterntabletop.com](mailto:sales@easterntabletop.com)

**Telephone:** 1-718-240-9595

**Toll Free:** 1-888-422-4142

**Corporate Headquarters, Showroom & Warehouse:**

*Eastern Tabletop Manufacturing Company Inc.*

*50 Ingham Avenue,*

*Bayonne NJ 07002.*